



FAIRBORN USA INC.

Fairborn USA Inc.
205 Broadview Street
Upper Sandusky, OH 43351
1-800-262-1188
Fax 1-419-294-4980

Series 1400L L-Pad Foam Dock Seal With Head Cap

All Models

Installation Instructions



Do not install this product unless you read and understand the Warnings and Installation Instructions contained in this manual. Failure to do so could result in serious injury or death.

SERIES 1400 FOAM DOCK SEAL

Installation Instructions

CHECK FIRST:

To ensure proper measurement to accommodate the Dock Seal you are installing, check the following:

A. Check the door height and width to verify that your side pads and head curtain are properly sized.

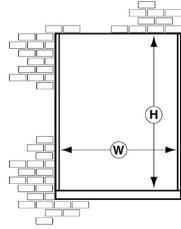

B. It is recommended that the head curtain or side pads be compressed not more than a maximum of 6"; nor more than 45% of its total projection. A minimum of 4" compression is advised to compensate for vehicles not evenly spotted against the building.

C. If the approach is not level, check to make sure the side pads taper to accommodate the angle of the truck. Also on a tapered drive, follow Step "B" for both the top and bottom of the seal, allowing for the recommended compression.

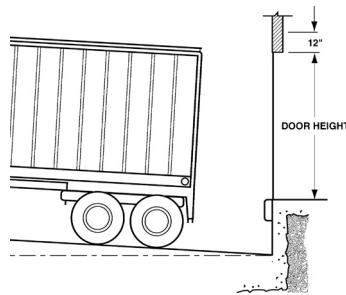

D. Check the heights of incoming carriers that will be utilized at this door, to ensure that the head curtain is of proper elevation to accommodate the height range of these vehicles.

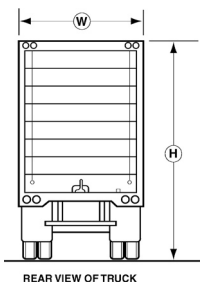

E. In 95% of installations, the inside edge of the face of the side pads should be 7'-6" I.D. If achieving the 7'-6" dimension requires extending the wood backing of the side pads into the door opening width, use the following recommendation:

Weld or anchor a structural angle the full length of the side jambs, not allowing any portion of the wood backing to be exposed into the door opening. It is appropriate to lag through the leg of the angle into the back of the wood approximately 1" from the edge of the board.

⚠ WARNING

Improper lifting or attachment of seal/shelter can cause serious injury or death.

Installation requires:

- A structurally sound building wall,
- Barricades to keep people away from the area,
- Proper attachment of anchoring devices,
- Two or more people,
- A lifting device capable of lifting at least 500 lbs. at the installation angle.

If you have questions, contact your supervisor, your local Fairborn distributor or Fairborn USA at 1-800-262-1188.

INSTALLATION:

1. Mark the center of the door opening on the dock floor.

2. From this center point, measure 3'-9" in each direction to determine the position of the side pads. This should give you a 7'-6" I.D. at the unit face.

3. If the side pad frames are flush with the door jamb, all standard mounting hardware can be utilized, which is normally (3) 3/32 x 3 x 5" Flat Mounting Brackets per Pad and (3) 3/32 x 3 x 1-1/2 x 3-1/2" Angle Mounting Brackets per Pad.

The flat brackets are secured by means of welding or anchoring into the doorjamb, allowing precisely 1-7/16" projecting away from the jamb. The flat brackets should be mounted with the slotted end against the jamb, and the end with two holes extending 1-7/16" away from the jamb. If the side pads are not flush with the doorjamb install angle or offset brackets by following Step 5.

4. After the jamb brackets have been installed, mount (3) of the angle brackets on the outside of the side pads. NOTE: There are right and left side pads. To distinguish between the two, the air pockets are to be on the outside of the pad, pointing down.

5. With the appropriate side pad, predrill and mount two of the angle brackets 1'-6" from each end, using the lag screws provided. The brackets should be mounted so the slotted leg will mount against the building face. When installing the angle brackets be sure to keep the slotted leg flush with the back of the seal.

6. With the angle brackets installed, hold pad in place tight against the premounted jamb brackets, then predrill into the wood backing and lag secure. Mount onto the face of the building through the slots with appropriate anchors.

7. With the side pads in place, mount the head cap. First, fasten three (3) eyebolt pulleys to furnished 2"x4". Mount one (1) in the center and space the remaining two (2) to correspond with the "O" ring spacing on the metal pipe sewn into the head cap. Secure 2x4 to building, across the top of side pads utilizing four (4) appropriate anchors, equally spaced, with the two outer anchors approximately 4" from each end (hardware furnished by installer). Place head cap over 2x4 and side pads and secure at stays with furnished lag screws and otherwise with furnished roofing nails, approximately 6" on center. Be sure to pull back the two (2) tie back straps at the outer face.

8. OPTIONAL SPLIT: If the unit is equipped with a split, attach the one (1) tie back flap at the inner face of each side pad and secure to side pad wood framing with furnished roofing nails, centering this section with the side pad face. (Refer to Illustration A.)

9. OPTIONAL PULL ROPES: Secure rope cleat to right side pad wood frame. (Refer to Illustration A.)

10. Route pull ropes per Illustration A and wrap on cleat to secure.

11. Caulk and fill all voids. Clean pads and hardware as required. Clear the dock area of any debris resulting from installation procedure.

SUGGESTED MOUNTING METHODS:

(Mounting anchors not included.)

Concrete or Brick Wall: Try to hit mortar joints. Use 1/2" or 3/8" x 3" expansion anchors. use through-bolt fastening if anchors will not hold, 3/8" threaded rod is recommended.

Precast Concrete: Same as above.

Metal Skin Building: Through-bolt fastening as above. Use a back-up plate (steel or wood) to support bolts or anchor through existing building horizontal and vertical structural members when possible.

NOTE: Dock Seals must have adequate bumper protection, 4" minimum.

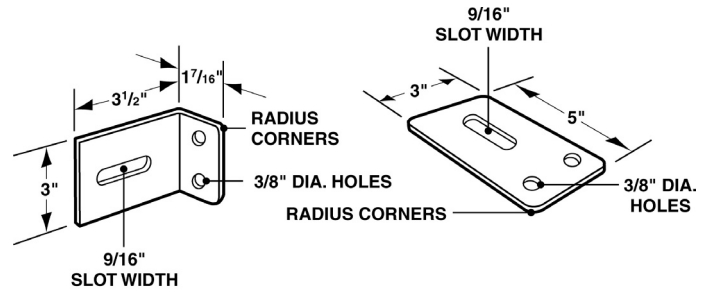

ANGLE AND FLAT MOUNTING BRACKETS

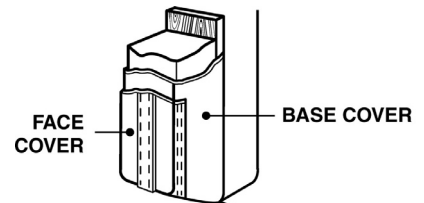
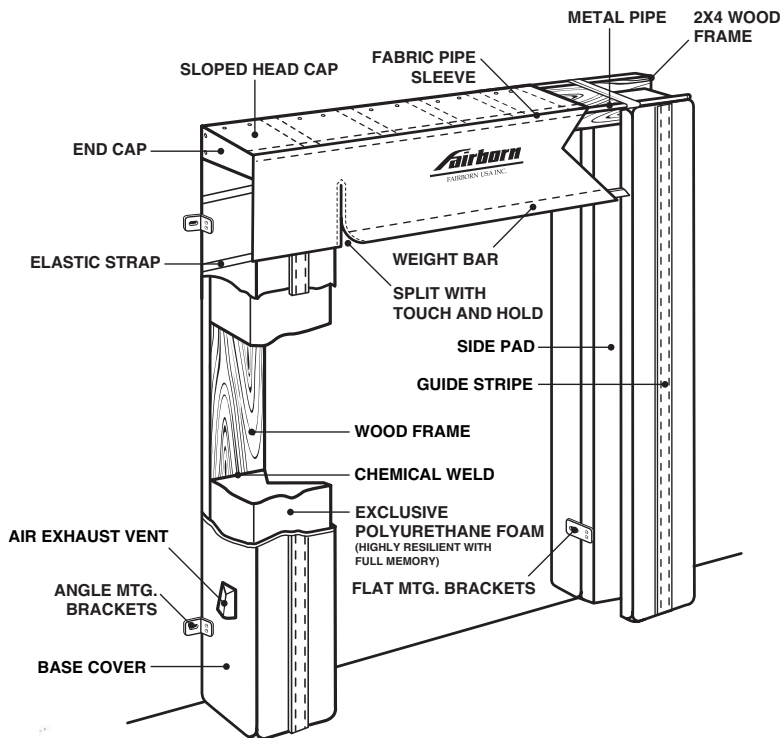

REINFORCED FACE

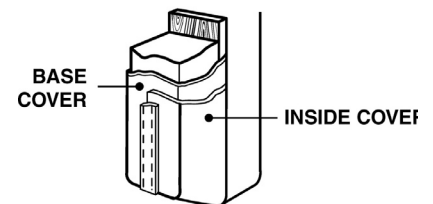

REINFORCED INSIDE

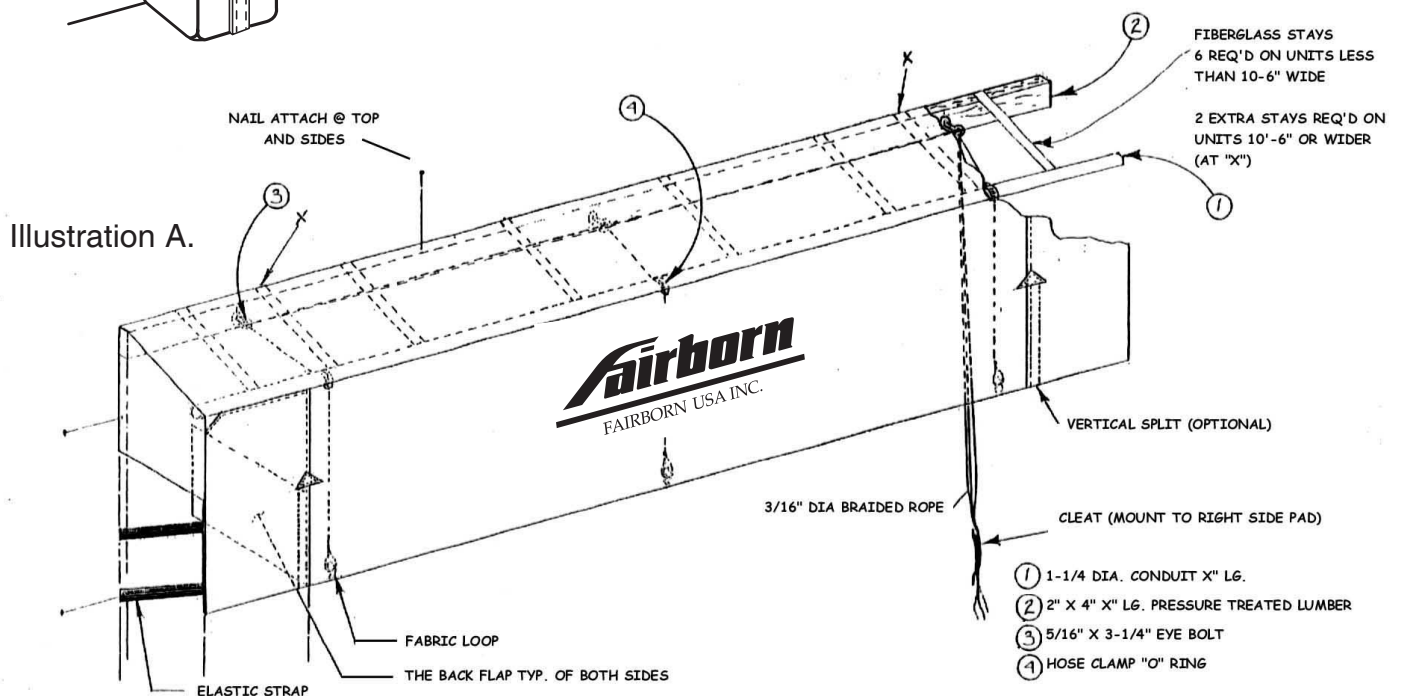

OPTIONAL DYNA-ARMOR® PLEAT:

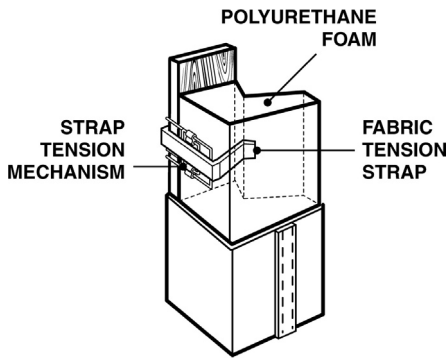

SIDE PAD COVER SUPPORT
(ASSEM. - TYP. 6 PLACES @ PAD)

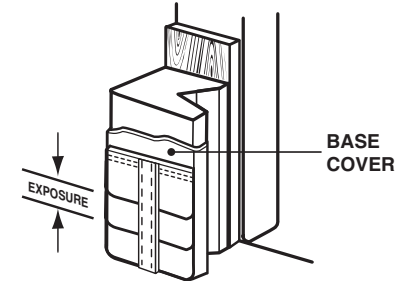

DYNA-ARMOR PLEATS

4" EXPOSURE
8" EXPOSURE
16" EXPOSURE

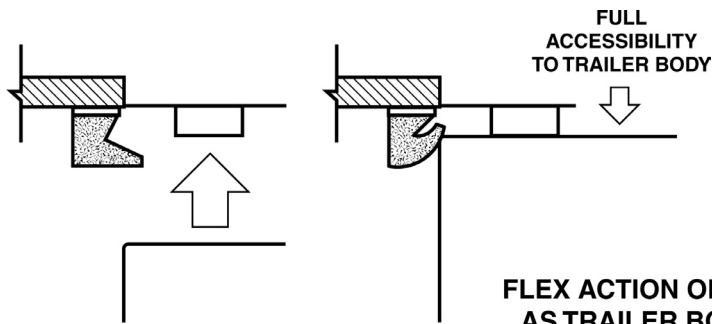

LIMITED PRODUCT WARRANTY

GENERAL

FAIRBORN USA INC. EXTENDS THIS LIMITED WARRANTY TO THE ORIGINAL BUYER AND WARRANTS THAT ALL PRODUCTS MANUFACTURED BY FAIRBORN SHALL BE FREE FROM ORIGINAL DEFECTS IN WORKMANSHIP AND MATERIALS FOR ONE YEAR FROM DATE OF SHIPMENT, PROVIDED SAME HAVE BEEN PROPERLY SIZED FOR THE APPLICATION, STORED, INSTALLED, SERVICED, MAINTAINED AND OPERATED. THIS WARRANTY SHALL NOT APPLY TO PRODUCTS WHICH HAVE BEEN ALTERED OR REPAIRED IN ANY WAY SO AS, IN FAIRBORN'S JUDGMENT, AFFECTS ITS PERFORMANCE OR RELIABILITY, NOR WHICH HAVE BEEN IMPROPERLY INSTALLED OR SUBJECTED TO MISUSE, NEGLIGENCE, OR ACCIDENT, OR INCORRECTLY USED IN COMBINATION WITH OTHER SUBSTANCES. COMPENSATION FOR PRODUCTS HAVING WEAR AND TEAR CAUSED BY NORMAL USAGE IS NOT PROVIDED FOR BY THIS WARRANTY.

DYNALON

IN CONSIDERATION OF THE SAME CONDITIONS AND RESTRICTIONS AS STATED ABOVE, DYNALON IS WARRANTED AGAINST THE EFFECTS OF WEATHERING FOR A PERIOD OF FIVE YEARS AS DESCRIBED WITHIN. AS PART OF THIS AGREEMENT THE TERM "WEATHERING" IS DEFINED AND LIMITED TO THE EFFECTS OF SUNLIGHT (ULTRAVIOLET RADIATION), WATER (ATMOSPHERIC PRECIPITATION), COLD, AND HEAT. THIS WARRANTY IS NOT APPLICABLE IF THE DYNALON HAS BEEN EXPOSED OR SUBJECTED TO CORROSIVE AGENTS, CHEMICALS, OR MECHANICAL ABUSE.

IN THE EVENT THAT THE EFFECTS OF WEATHERING RENDER THE PRODUCT, CONSTRUCTED OF DYNALON, INOPERABLE DUE TO CRACKING, CHECKING, OR ULTRAVIOLET BREAKDOWN, THEN FAIRBORN USA INC., AFTER INSPECTION AND VERIFICATION, WILL FURNISH REPLACEMENT MATERIALS, AT NO COST TO CUSTOMER, TO FIX OR REPAIR AND/OR REPLACE THE INOPERABLE COMPONENTS. FAIRBORN SHALL NOT BE RESPONSIBLE FOR THE ON-SITE LABOR, FREIGHT, LOSS OF USE OR ANY OTHER EXPENSE RELATED TO THE AFOREMENTIONED CLAIM.