



FAIRBORN USA INC.

Fairborn USA Inc.
205 Broadview Street
Upper Sandusky, OH 43351
1-800-262-1188
Fax 1-419-294-4980

Series 3000 Flexible Dock Shelter

All Models

Installation Instructions



Do not install this product unless you read and understand the Warnings and Installation Instructions contained in this manual. Failure to do so could result in serious injury or death.

SERIES 3000 FLEXIBLE TRUCK SHELTER

Installation Instructions

CHECK FIRST:

To ensure proper measurement to accommodate the Dock Shelter you are installing, check the following:

A. Check the door height and width to verify that your shelter frame is properly sized.

B. It is recommended that the shelter frame project 14"-18" beyond the dock bumper. (Example: At a flush dock with a bumper projection of 6", standard shelter projection should be 20"-24" for standard 11' 6" wide shelter.)

C. If the approach is not level, check to make sure shelter frame tapers to accommodate the angle of the truck.

D. Check the heights of incoming carriers that will be utilized at this door, to ensure that the shelter frame is of proper elevation to accommodate the height range of these vehicles. The top of a Flexible Wood Frame Shelter should be kept as close to 15' 0" off grade as possible.

E. In 95% of installations, the inside edge of the face of the side curtain should be 7' 0" I.D.

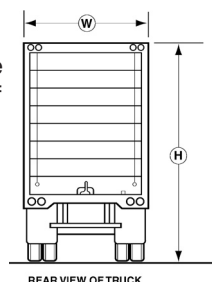
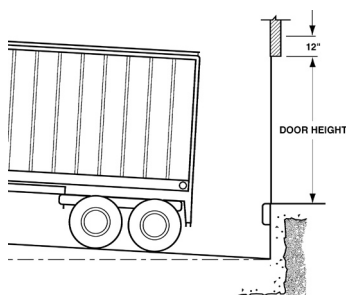
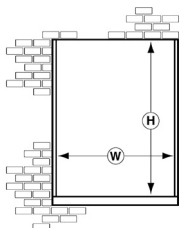

INSTALLATION:

1. Determine center of door opening on dock floor.
2. Determine position of the outside edges of unit: Take 1/2 of the given unit width and mark off this distance both ways from the centerline.
3. Attach foam bottom pads to side members, using carriage bolts and wood screws provided. (Reference attached Specification Sheet)
4. Attach left side member to wall. Place the outside edge of the left side member on the mark measured from the center of the door opening, and the bottom of side member flush with dock floor. Plumb the side member. Drill three 5/8" holes (or more when over 10'-6" high) through the side member and into the wall. Try to hit a mortar joint. Fasten the side member to the wall with three (3) anchors, appropriate to the building construction (minimum 3/8" diameter) - one in the middle and one each near the top and bottom. Stagger screws so that they are not in the same line on side member.

NOTE: Be careful not to allow the member to get out of plumb or off the marks previously determined.

NOTE: When fastening side and head members to metal or any thin wall faced building, a wood or other type spacer should be located on the inside of the building wall. This spacer should be large enough to keep bolts going through building to fasten side and head members from pulling through the building material.

5. Attach the right side member to wall, using the same procedure as outlined in Step 3.
6. Install head member. The head member will fit between the side members and flush with the top. Fasten to wall with three appropriate anchors - one near the middle and one each near the ends.

NOTE: It is recommended that the head member be caulked to seal any spaces between member and wall.

7. Assemble the cover to the top frame cross bar; hole spacing in pipe is symmetrical. Lay the cover out on the floor. Position the top frame cross bar inside cover and fasten cover to bar with the furnished bolts, washers and nuts. The pre-drilled holes in the bar will align with the grommets in the cover.
8. Assemble the cover and top frame cross bar to the upper pivot arms; loosen the set screws in the slip tees and place on the pivot arms. Before tightening set screws in slip tees, move the pivot arms to their farthest "in" or "out" position to eliminate any binding and then tighten the set screws.
9. Fasten cover to frame members; roofing nails are included for fastening cover to members. Space nails approximately 6" apart.

⚠ WARNING

Improper lifting or attachment of seal/shelter can cause serious injury or death.

Installation requires:

- A structurally sound building wall,
- Barricades to keep people away from the area,
- Proper attachment of anchoring devices,
- Two or more people,
- A lifting device capable of lifting at least 500 lbs. at the installation angle.

If you have questions, contact your supervisor, your local Fairborn distributor or Fairborn USA at 1-800-262-1188.

10. Fasten corners of lower cover to lower custom arms. Remove the screws from the end caps and position the lower grommets in the cover over the holes. Secure cover with screws.

11. Hook tension springs on upper and lower pivot arms to screw eyes. Spring tension can be increased by dropping links in chain.

12. Caulk and fill all voids. Clean pads and hardware as required. Clear the dock area of any debris resulting from installation procedure.

NOTE: Parts are marked right or left. Directions are made facing the door from the outside of the building.

SUGGESTED MOUNTING METHODS:

(Mounting anchors not included.)

Concrete or Brick Wall: Try to hit mortar joints. Use 1/2" or 3/8" x 3" expansion anchors. use through-bolt fastening if anchors will not hold, 3/8" threaded rod is recommended.

Precast Concrete: Same as above.

Metal Skin Building: Through-bolt fastening as above. Use a back-up plate (steel or wood) to support bolts or anchor through existing building horizontal and vertical structural members when possible.

NOTE: Dock Seals must have adequate bumper protection, 4" minimum.

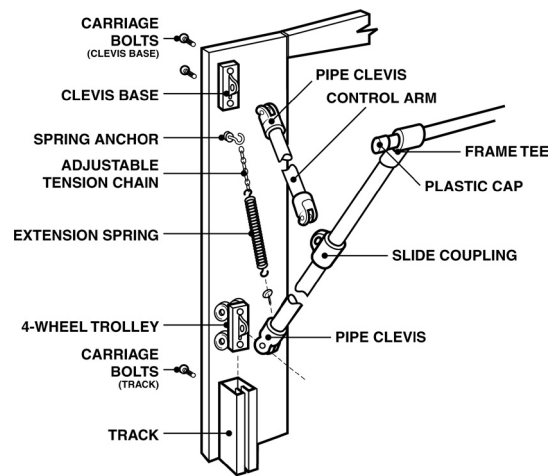
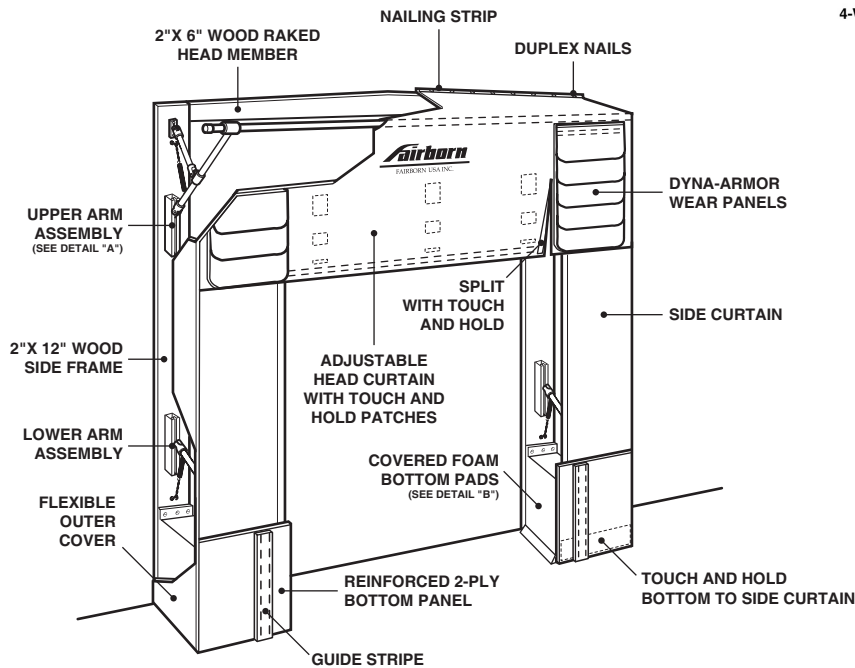

DETAIL "A"
UPPER ARM ASSEMBLY

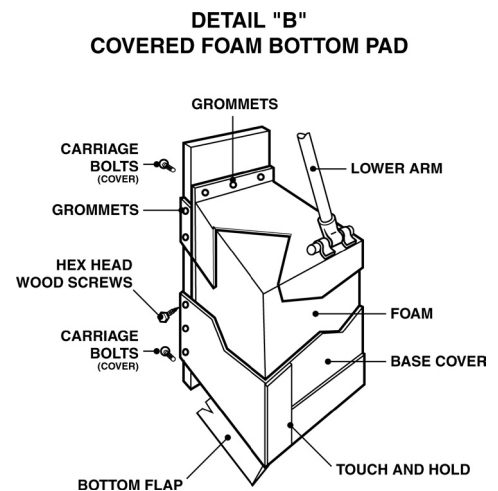

DETAIL "B"
COVERED FOAM BOTTOM PAD

OPTIONAL COMMON SIDE MEMBER:

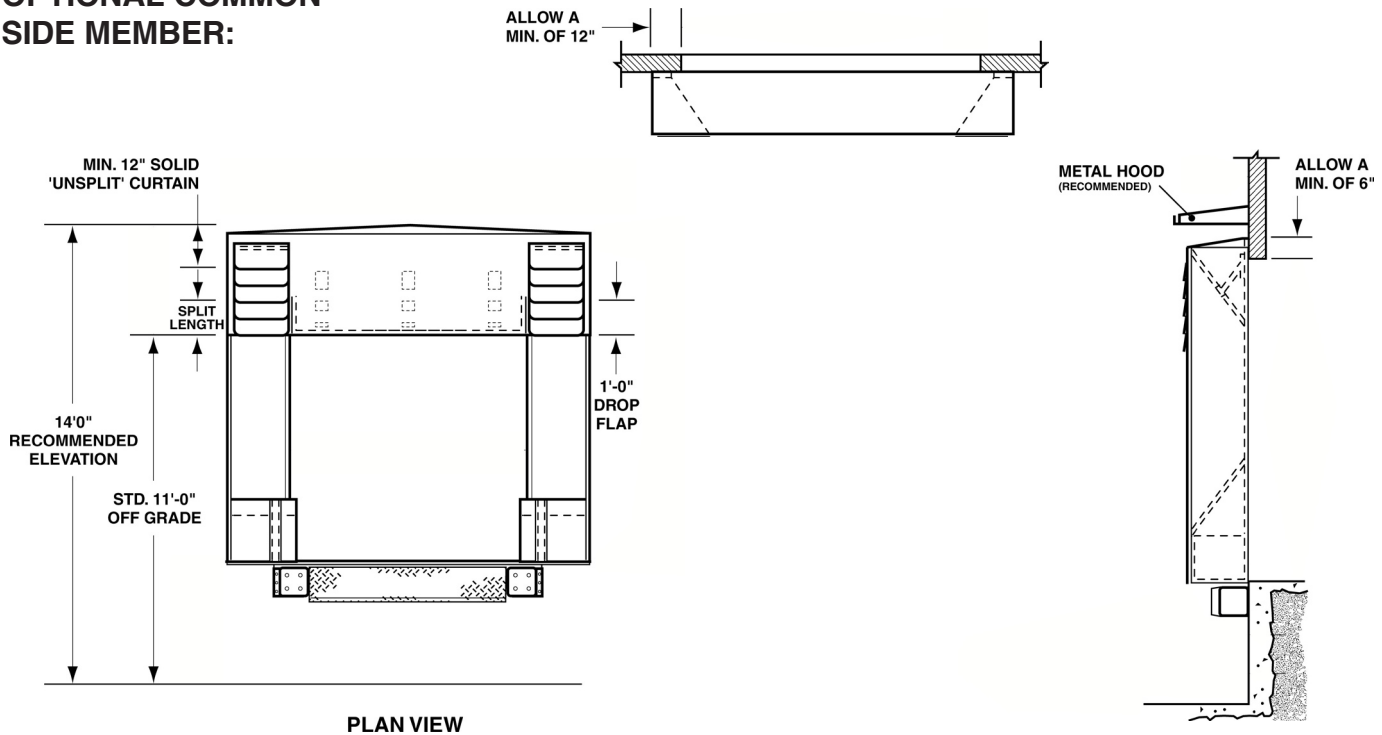

LIMITED PRODUCT WARRANTY

GENERAL

FAIRBORN USA INC. EXTENDS THIS LIMITED WARRANTY TO THE ORIGINAL BUYER AND WARRANTS THAT ALL PRODUCTS MANUFACTURED BY FAIRBORN SHALL BE FREE FROM ORIGINAL DEFECTS IN WORKMANSHIP AND MATERIALS FOR ONE YEAR FROM DATE OF SHIPMENT, PROVIDED SAME HAVE BEEN PROPERLY SIZED FOR THE APPLICATION, STORED, INSTALLED, SERVICED, MAINTAINED AND OPERATED. THIS WARRANTY SHALL NOT APPLY TO PRODUCTS WHICH HAVE BEEN ALTERED OR REPAIRED IN ANY WAY SO AS, IN FAIRBORN'S JUDGMENT, AFFECTS ITS PERFORMANCE OR RELIABILITY, NOR WHICH HAVE BEEN IMPROPERLY INSTALLED OR SUBJECTED TO MISUSE, NEGLIGENCE, OR ACCIDENT, OR INCORRECTLY USED IN COMBINATION WITH OTHER SUBSTANCES. COMPENSATION FOR PRODUCTS HAVING WEAR AND TEAR CAUSED BY NORMAL USAGE IS NOT PROVIDED FOR BY THIS WARRANTY.

DYNALON

IN CONSIDERATION OF THE SAME CONDITIONS AND RESTRICTIONS AS STATED ABOVE, DYNALON IS WARRANTED AGAINST THE EFFECTS OF WEATHERING FOR A PERIOD OF FIVE YEARS AS DESCRIBED WITHIN. AS PART OF THIS AGREEMENT THE TERM "WEATHERING" IS DEFINED AND LIMITED TO THE EFFECTS OF SUNLIGHT (ULTRAVIOLET RADIATION), WATER (ATMOSPHERIC PRECIPITATION), COLD, AND HEAT. THIS WARRANTY IS NOT APPLICABLE IF THE DYNALON HAS BEEN EXPOSED OR SUBJECTED TO CORROSIVE AGENTS, CHEMICALS, OR MECHANICAL ABUSE.

IN THE EVENT THAT THE EFFECTS OF WEATHERING RENDER THE PRODUCT, CONSTRUCTED OF DYNALON, INOPERABLE DUE TO CRACKING, CHECKING, OR ULTRAVIOLET BREAKDOWN, THEN FAIRBORN USA INC., AFTER INSPECTION AND VERIFICATION, WILL FURNISH REPLACEMENT MATERIALS, AT NO COST TO CUSTOMER, TO FIX OR REPAIR AND/OR REPLACE THE INOPERABLE COMPONENTS. FAIRBORN SHALL NOT BE RESPONSIBLE FOR THE ON-SITE LABOR, FREIGHT, LOSS OF USE OR ANY OTHER EXPENSE RELATED TO THE AFOREMENTIONED CLAIM.